

CURRENT OWNER				TOPO	UTILITIES	STRT / ROAD	LOCATION	CURRENT ASSESSMENT				
CASTILLO HOLDINGS LLC								Description	Code	Appraised	Assessed	801 FY2023 BARNSTABLE, MA
4888 DAVIS BLVD SUITE 286								RESIDNTL	0111	471,510	471,510	
NAPLES FL 34104								RES LAND	0111	125,346	125,346	
				<b>SUPPLEMENTAL DATA</b>				COMMERC.	031M	737,490	737,490	
				Alt Prcl ID Split Zonin BID Parcel ResExpt Q #DL 1 STHRLY P/O LOT D #DL 2 GIS ID F_986654_2699678				Plan Ref. 71/63 Land Ct# #SR Life Estate PP STATU Assoc Pid#	COMMERC.	031M	196,054	
									031R	190,800	190,800	<b>VISION</b>
								Total		1,721,200	1,721,200	

RECORD OF OWNERSHIP							BK-VOL/PAGE	SALE DATE	Q/U	V/I	SALE PRICE	VC	PREVIOUS ASSESSMENTS (HISTORY)									
CASTILLO HOLDINGS LLC							33875	261	03-10-2021	U	I	1	1F	Year	Code	Assessed	Year	Code	Assessed	Year	Code	Assessed
SOLIMINI, CHRIS TR							33875	259	03-10-2021	U	I	0	1F	2023	0111	471,510	2022	0111	351,507	2021	0111	340,080
BARRETT, ROBERT J TR							31510	0287	09-05-2018	U	I	800,000	1V		0111	125,346		0111	125,346		0111	125,346
CHILLI, JEANNETTE F							29746	0280	06-23-2016	U	I	0	1A		031M	737,490		031M	549,793		031M	531,920
CHILLI, JOSEPH I & JEANNETTE F							3409	0062	12-15-1981	Q		160,000	U		031M	196,054		031M	196,054		031M	196,054
								Total				1,721,200	Total				1,369,400	Total				1,340,100

EXEMPTIONS				OTHER ASSESSMENTS				This signature acknowledges a visit by a Data Collector or Assessor												
Year	Code	Description	Amount	Code	Description	Number	Amount	Comm Int												
Total			0.00																	

ASSESSING NEIGHBORHOOD				APPROAISED VALUE SUMMARY			
Nbhd	Nbhd Name	B	Tracing	Batch			
CI11				HYAN			

NOTES												APPROAISED VALUE SUMMARY			
2 STOREFRONTS												Appraised Bldg. Value (Card)	1,399,800		
5 APTS												Appraised Xf (B) Value (Bldg)	0		
												Appraised Ob (B) Value (Bldg)	0		
												Appraised Land Value (Bldg)	321,400		
												Special Land Value	0		
												Total Appraised Parcel Value	1,721,200		
												Valuation Method	C		
												Total Appraised Parcel Value	1,721,200		

BUILDING PERMIT RECORD										VISIT / CHANGE HISTORY					
Permit Id	Issue Date	Type	Description	Amount	Insp Date	% Comp	Date Comp	Comments	Date	Id	Type	Is	Cd	Purpost/Result	
BLDC-22-79	06-13-2022	803	Addn Alt-Comm	2,300		100		move bath (non-wet) wall to pr	09-13-2021	BM	22		22	Change of Address	
19-2340	07-19-2019	835	Sid/Wind/Roof/	21,800		100		siding, windows, roof - dumpst	07-03-2021	CK	02		03	Cycl Insp Comp	
16-2099	07-22-2016	836	Sign	0	06-30-2017	100	06-30-2017	New hanging sign 7 sq ft Eclec	05-06-2020	GM	04		FR	Field Review	
20060982	06-16-2006	RE	Remodel	70,000	06-30-2008	100	06-30-2008		08-25-2015	AL	03		16	In Office Review	
40445	08-17-1999	NR	New Roof	3,200	01-01-2000	100	12-31-2000		06-19-2015	JR	03		03	Cycl Insp Comp	
28207	01-07-1998	AD	Addition	10,000	01-01-1999	100	12-31-1999	ENCLOSE PATIO	11-04-2008	JG	03		09	Permit Entered	
B26356	04-01-1984	AD	Addition	2,000	01-15-1986	100	12-31-1986	HY ADDN	05-03-2007	JK	03		16	In Office Review	

LAND LINE VALUATION SECTION																		
B	Use Code	Description	Zone	LA	Land Type	Land Units	Unit Price	I. Factor	Site Index	Cond.	Nbhd.	Nbhd Adj	Notes	Location Adjustme	Adj Unit Pric	Land Value		
1	031M	MU RET/OFFC	HVB	4		0.290	AC	330,000.00	2.03552	C	1.50	CI11	1.100	IU		0	1,108,338	321,400
Total Card Land Units						12,632	SF	Parcel Total Land Area: 0.29						Total Land Value		321,400		

CONSTRUCTION DETAIL			CONSTRUCTION DETAIL (CONTINUED)		
Element	Cd	Description	Element	Cd	Description
Style	80	Mixed Use			
Model	94	Commercial			
Grade	C	Average			
Stories	2				
Occupancy	7.00				
Exterior Wall 1	14	Wood Shingle			
Exterior Wall 2					
RooF Structure	03	Gable/Hip			
RooF Cover	03	Asph/F Gls/Cmp			
Interior Wall 1	05	Drywall			
Interior Wall 2					
Interior Floor 1	12	Hardwood			
Interior Floor 2	11	Ceram Clay Til			
Heating Fuel	03	Gas			
Heating Type	04	Hot Air			
AC Type	03	Central			
Size Adj Tbl	031M	MU RET/OFFC			
Total Rooms					
Bedrooms	01				
Full Bathrooms	0				
Bath Split	00	0 Full-0 Half			
Rms/Partitions	04	EXTENSIVE			
Heat/AC	01	HEAT/AC PKGS			
Frame Type	02	WOOD FRAME			
Baths/Plumbing	04	EXTENSIVE			
Ceiling/Wall	06	CEIL & WALLS			
Common Wall	02	10%			
Wall Height	10.00				
1st Floor Use:	032L				

MIXED USE		
Code	Description	Percentage
031M	MU RET/OFFC	61
0111	APTS 4-8 RES TYP	39
		0

COST / MARKET VALUATION	
RCN	1,633,800
Year Built	1940
Effective Year Built	1986
Depreciation Code	G
Remodel Rating	
Year Remodeled	
Depreciation %	26
Functional Obsol	0
External Obsol	0
Trend Factor	1
Condition	
Condition %	
Percent Good	74
RCNLD	1,209,000
Dep % Ovr	
Dep Ovr Comment	
Misc Imp Ovr	
Misc Imp Ovr Comment	
Cost to Cure Ovr	
Cost to Cure Ovr Comment	

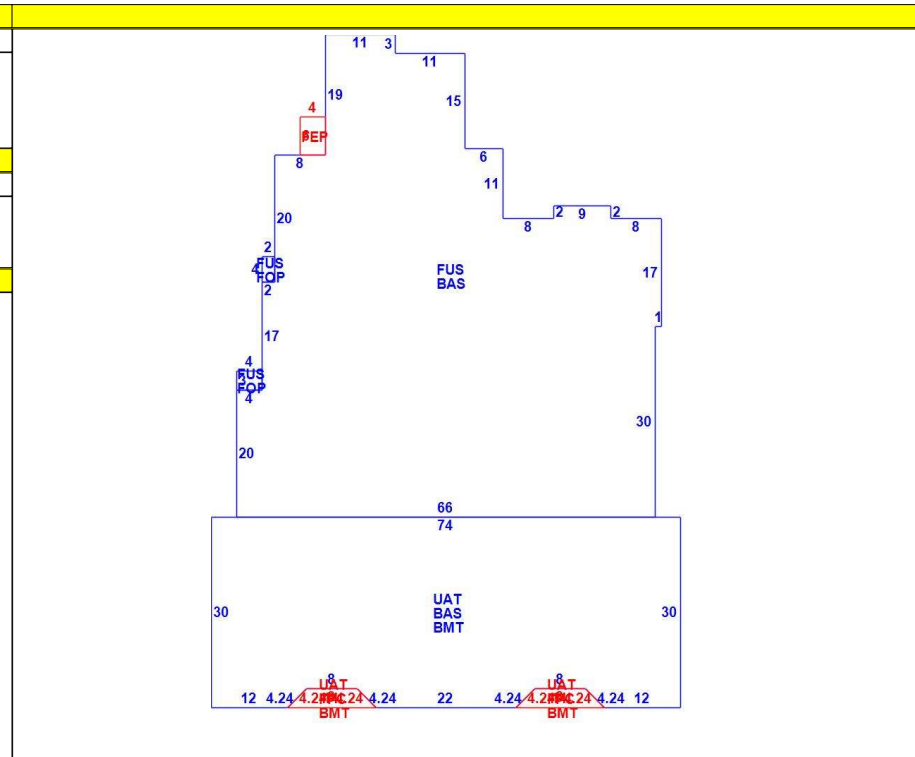

OB - OUTBUILDING & YARD ITEMS(L) / XF - BUILDING EXTRA FEATURES(B)										
Code	Description	L/B	Units	Unit Price	Yr Blt	Cond. Cd	% Good	Grade	Grade Adj	Appr. Value

BUILDING SUB-AREA SUMMARY SECTION							
Code	Description	Living Area	Floor Area	Eff Area	Unit Cost	Undeprec Value	
BAS	First Floor	5,914	5,914	5,914	155.23	918,033	
BMT	Basement Area	0	2,220	444	31.05	68,922	
FEP	Enclosed Porch	0	24	8	51.74	1,242	
FOP	Open Porch	0	20	3	23.28	466	
FPC	Open Porch Conc. Floor	0	66	10	23.52	1,552	
FUS	Upper Story	3,780	3,780	3,591	147.47	557,432	
UAT	Attic, Unfinished	0	2,220	555	38.81	86,153	
Ttl Gross Liv / Lease Area		9,694	14,244	10,525		1,633,800	



CURRENT OWNER				TOPO	UTILITIES	STRT / ROAD	LOCATION	CURRENT ASSESSMENT				
CASTILLO HOLDINGS LLC								Description	Code	Appraised	Assessed	801 FY2023 BARNSTABLE, MA
4888 DAVIS BLVD SUITE 286								RESIDNTL	0111	471,510	471,510	
NAPLES FL 34104								RES LAND	0111	125,346	125,346	
				<b>SUPPLEMENTAL DATA</b>				COMMERC.	031M	737,490	737,490	
Alt Prcl ID Split Zonin BID Parcel ResExpt Q #DL 1 STHRLY P/O LOT D #DL 2 GIS ID F_986654_2699678				Plan Ref. 71/63 Land Ct# #SR Life Estate PP STATU Assoc Pid#				COM LAND	031M	196,054	196,054	
								COMMERC.	031R	190,800	190,800	<b>VISION</b>
								Total		1,721,200	1,721,200	

RECORD OF OWNERSHIP							BK-VOL/PAGE	SALE DATE	Q/U	V/I	SALE PRICE	VC	PREVIOUS ASSESSMENTS (HISTORY)									
CASTILLO HOLDINGS LLC							33875	261	03-10-2021	U	I	1	1F	Year	Code	Assessed	Year	Code	Assessed	Year	Code	Assessed
SOLIMINI, CHRIS TR							33875	259	03-10-2021	U	I	0	1F	2023	0111	471,510	2022	0111	351,507	2021	0111	340,080
BARRETT, ROBERT J TR							31510	0287	09-05-2018	U	I	800,000	1V		0111	125,346		0111	125,346		0111	125,346
CHILLI, JEANNETTE F							29746	0280	06-23-2016	U	I	0	1A		031M	737,490		031M	549,793		031M	531,920
CHILLI, JOSEPH I & JEANNETTE F							3409	0062	12-15-1981	Q		160,000	U		031M	196,054		031M	196,054		031M	196,054
								Total				1,721,200	Total				1,369,400	Total				1,340,100

EXEMPTIONS				OTHER ASSESSMENTS				This signature acknowledges a visit by a Data Collector or Assessor												
Year	Code	Description	Amount	Code	Description	Number	Amount	Comm Int												
Total			0.00																	

ASSESSING NEIGHBORHOOD				APPRAISED VALUE SUMMARY			
Nbhd	Nbhd Name	B	Tracing	Batch			
CI11				HYAN	Appraised Bldg. Value (Card)	1,399,800	
					Appraised Xf (B) Value (Bldg)	0	
					Appraised Ob (B) Value (Bldg)	0	
					Appraised Land Value (Bldg)	321,400	
					Special Land Value	0	
					Total Appraised Parcel Value	1,721,200	
					Valuation Method	C	
					Total Appraised Parcel Value	1,721,200	

NOTES												VISIT / CHANGE HISTORY				
Permit Id	Issue Date	Type	Description	Amount	Insp Date	% Comp	Date Comp	Comments	Date	Id	Type	Is	Cd	Purpost/Result		
RESTAURANT																

BUILDING PERMIT RECORD												VISIT / CHANGE HISTORY				
Permit Id	Issue Date	Type	Description	Amount	Insp Date	% Comp	Date Comp	Comments	Date	Id	Type	Is	Cd	Purpost/Result		

LAND LINE VALUATION SECTION																		
B	Use Code	Description	Zone	LA	Land Type	Land Units	Unit Price	I. Factor	Site Index	Cond.	Nbhd.	Nbhd Adj	Notes	Location Adjustme	Adj Unit Pric	Land Value		
2	031R	MU RESTAURA	HVB	4		0 SF	0.00	1.00000	0	1.00		1.000		0	0	0		
Total Card Land Units						0 SF	Parcel Total Land Area: 0.29						Total Land Value					321,400

CONSTRUCTION DETAIL			CONSTRUCTION DETAIL (CONTINUED)		
Element	Cd	Description	Element	Cd	Description
Style	30	Restaurant			
Model	94	Commercial			
Grade	C	Average			
Stories	1				
Occupancy	1.00				
Exterior Wall 1	14	Wood Shingle			
Exterior Wall 2					
Roof Structure	03	Gable/Hip			
Roof Cover	03	Asph/F Gls/Cmp			
Interior Wall 1	08	Typical			
Interior Wall 2					
Interior Floor 1	20	Typical			
Interior Floor 2					
Heating Fuel	06	Typical			
Heating Type	09	Typical			
AC Type	01	None			
Size Adj Tbl	031R	MU RESTAURANT			
Total Rooms					
Bedrooms	01				
Full Bathrooms	0				
Bath Split	00	0 Full-0 Half			
Rms/Partitions	02	AVERAGE			
Heat/AC	03	HEAT ONLY			
Frame Type	02	WOOD FRAME			
Baths/Plumbing	02	AVERAGE			
Ceiling/Wall	08	TYPICAL			
Common Wall	00	0%			
Wall Height	8.00				
1st Floor Use:	0325				

MIXED USE		
Code	Description	Percentage
031R	MU RESTAURANT	100
		0
		0

COST / MARKET VALUATION	
RCN	250,996
Year Built	1950
Effective Year Built	1988
Depreciation Code	G
Remodel Rating	04
Year Remodeled	2007
Depreciation %	24
Functional Obsol	0
External Obsol	0
Trend Factor	1
Condition	
Condition %	
Percent Good	76
RCNLD	190,800
Dep % Ovr	
Dep Ovr Comment	
Misc Imp Ovr	
Misc Imp Ovr Comment	
Cost to Cure Ovr	
Cost to Cure Ovr Comment	

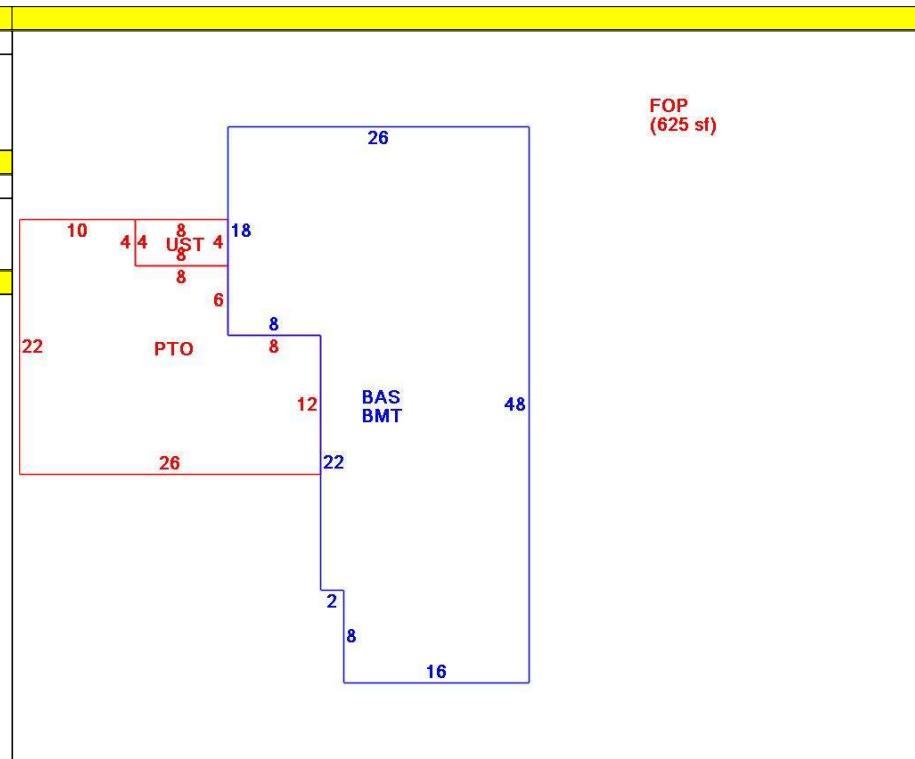

OB - OUTBUILDING & YARD ITEMS(L) / XF - BUILDING EXTRA FEATURES(B)										
Code	Description	L/B	Units	Unit Price	Yr Blt	Cond. Cd	% Good	Grade	Grade Adj	Appr. Value

BUILDING SUB-AREA SUMMARY SECTION							
Code	Description	Living Area	Floor Area	Eff Area	Unit Cost	Undeprec Value	
BAS	First Floor	992	992	992	191.60	190,067	
BMT	Basement Area	0	992	198	38.24	37,937	
FOP	Open Porch	0	625	94	28.82	18,010	
PTO	Patio	0	460	23	9.58	4,407	
UST	Utility Enclosure	0	32	3	17.96	575	
Ttl Gross Liv / Lease Area		992	3,101	1,310		250,996	

